

NAVA News

North American Vexillological Association

john r b szala editor
284 crittenden way #6
rochester n y 14623



.....
Volume IX, No. 4
.....

.....
October-December - 1976
.....

NAVA MEMBER DESIGNS FLAGS for three communities -

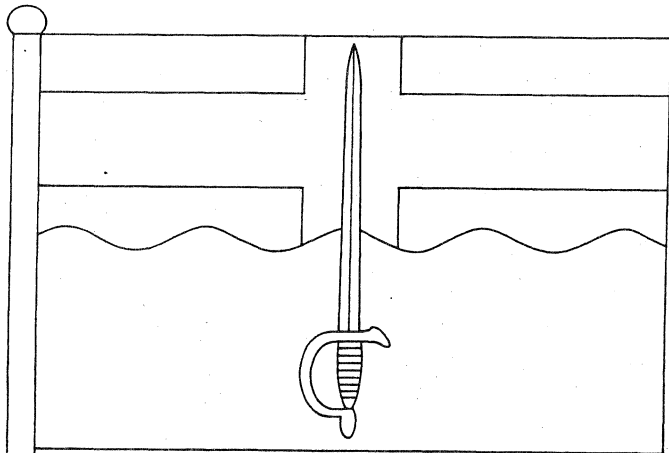

CLARKSVILLE, INDIANA

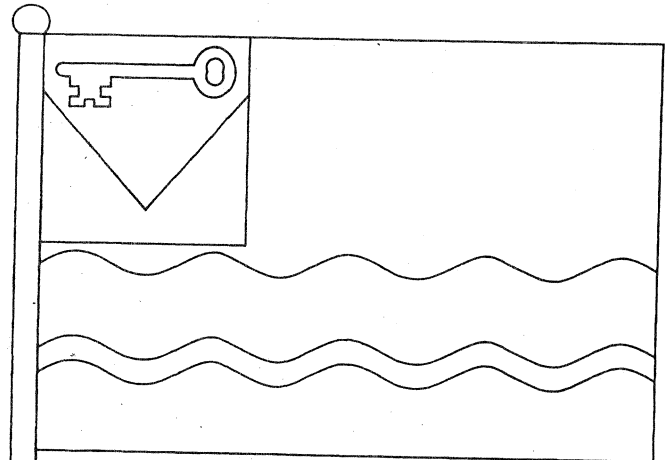

MIDDLETOWN, KENTUCKY

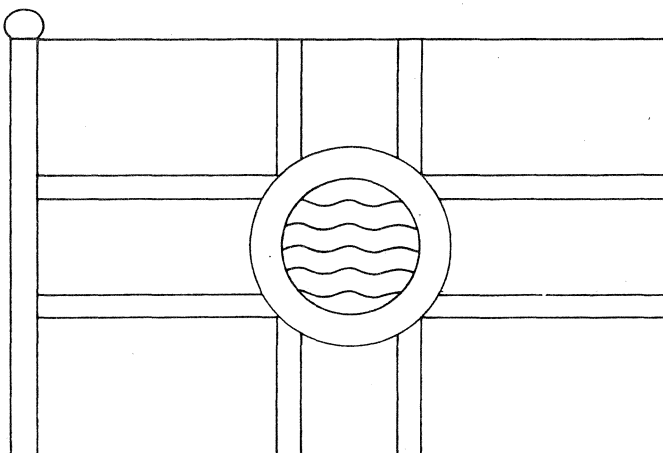

OLDHAM COUNTY, KENTUCKY

Dick Crossett is a free-lance Advertising Designer in Louisville, Kentucky who is interested in good heraldry and flag design because of its graphic relationship to contemporary design communication has in recent years designed the flags for the Town of Clarksville, Indiana, Middletown, Kentucky and Oldham County, Kentucky.

Mr. Crossett served in the 11th Armored Division in Europe during World War II and with the 1st Cavalry Division in Japan during the Korean Emergency. He is a native of Arkansas and a 1950 graduate in Art from the University of Arkansas.

The flag for the Town of Clarksville, Indiana is divided horizontally, wavy white and blue. The white portion bears a red Cross of St. George. Overall, in the center is a vertical gold sword, point to chief (top).

The color blue and the wavy division line suggests the Ohio River. The Cross of St. George indicates the site of Clarksville on the north bank on land granted to George Rogers Clark by Colonial Virginia for his services against the English in the American Revolution. This Cross appears on the arms of early Virginia and it has also traditionally symbolized the English who originally controlled the area north of the Ohio River known as the "Illinois Country." The gold sword, another gift for Clark's military service, is also an allusion to the General and his men who were known as the "Kentucky Long Knives", and who departed for the campaign against the English from the vicinity of the present town of Clarksville in June of 1778.

The flag of Middletown, Kentucky is yellow in its upper portion and below it are wavy horizontal bars of green, white and blue. In the upper left is a red and blue canton, with a white key.

The yellow area and wavy bars symbolize the sunny, rolling hills and streams of Middletown.

The canton suggests a sign hanging before a tavern, and with the key, suggests Middletown's heritage as a midway stop for travelers in the early days.

Oldham County's flag was adopted in 1974. Its description is as follows: On a green field a red Cross of St. George fimbriated white bearing in the center a heraldic fountain within a yellow annulet.

Green is for the fields of Oldham County. The fountain, a heraldic symbol for a pool or spring, represents LaGrange, the county seat which was founded by William Berry Taylor on the site of what was called "The Public Spring". It is placed within a yellow annulet which represents the sun as well as suggesting the letter "O". The red Cross of St. George symbolizes the cross roads location of LaGrange and it was also part of the coat-of-arms of Colonial Virginia, the birthplace of Col. William Oldham for whom the county was named.

.....

The following NAVA members were featured in newspaper articles during the past few months:

TEDD CHRISTENSEN - Chicago Sun Times (7-27-75)

FRANK TROTTER - Oracle, Orleans, Mass. (12-18-75)

C. GUY CROSS - Quincy Herald Whig (7-20-75)
Quincy, Illinois

JAMES W. BRODERICK - Empire Magazine (6-27-76)

JOHN L. CROSS - Provo Daily Herald (4-22-75)
Provo, Utah

BOB WEATON - Des Moines Sunday Register
(7-6-75)

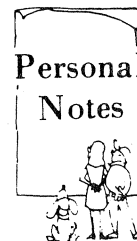

BETSY ROSS is featured on a Schmidt's beer can by the C. Schmidt & Sons, Inc. firm of Philadelphia, Pennsylvania. The caption under her picture reads: "Birth of our nation's flag".



Individual liberty rampant in the earliest American flags

By Lita Solis-Cohen
Inquirer Antiqua Writer

One of the major problems involved in writing about the history of the flag — and collectors of early flags — is how to deal with Betsy Ross.

The problem is that lots of rather excitable people believe that Ms. Ross made the first flag, under the stern and earnest direction of George Washington himself, despite the fact that there isn't a scintilla of evidence to support this charming old tale.

For the present I intend to evade the problem in this pre-Flag Day briefing by placing the full responsibility on the Indians.

And rightly so. No matter who actually made the first flag, they did it to fill an order sent in to the Continental Congress in the spring of 1777 by Indians. To expedite matters the Indians sent along three strings of wampum to cover the cost.

The Indian request, stating that they felt it was high time that the new nation had a flag of its own, was put before the Congress on June 3, 1777, and 11 days later the flag resolution was passed.

"Resolved: That the flag of the United States be 13 stripes alternate red and white, that union be 13 stars in a blue field, representing a new constellation."

The catch was that neither the Congress, Betsy Ross, George Washington, or anyone else specified how the stars should be placed. People could do it any way they wanted to — and they did. It was one of the ways in which individual liberty was to be reflected in the new nation, and the fact that the early flags were so varied has created a fascinating field for collectors.

Few circles

One thing does seem certain: A circle was not the first idea that Americans came up with. None of

Antiques

the surviving flags of the Revolutionary era have the stars in this configuration, though there is a painting of one. A circle of 12 stars with a larger star in the center was popular and so was a staggered pattern. The only claim of authorship for a star pattern presented to the Congress came from Francis Hopkinson, a Philadelphia patriot, poet, lawyer, and all-around overachiever, who asked the Congress to give him a "quarter cask of the public wine" for coming up with a plan of arranging the stars in a quincunial staggered pattern.

The Congress did not come up with the plan for the flag out of a clear blue field, so to speak. The troops under Washington had been using the so-called Grand Union, which had 13 red and white stripes, with the British union of crosses — St. George's for England and St. Andrew's for Scotland — in the upper left-hand corner. The daffodil-yellow flag of Philadelphia's First City troop also had 13 stripes—in silver and blue—in the upper left-hand corner.

The use of a five-pointed star, which is also ascribed to Ms. Ross, was undoubtedly an innovation in flag-making, stars up to that point having had six or eight points. Betsy is supposed to have sold Gen. Washington on five-pointed stars on the ground that it was easier to make, since it could be created with a single snip of the scissors.

The chances are just as good, though, that if there is any truth to the Washington-Ross collaboration that Washington may have been the one who came up with the idea.

Design spelled out

A five-pointed shape was in use in

heraldry at the time, representing, in the narrow sense, the rowel or "molet" of a spur, and in the broader sense, the spirit of chivalry. The five-pointed device appears on the Washington family coat of arms.

At all events, the flag continued to wave and evolve after the Revolution in accordance with the acts of Congress and at the whim of individual flagmakers until the government took a lot of the fun and originality out of flagmaking with the Flag Act of 1912, which finally spelled everything out.

The prices that are being paid for flags have remained stable, somewhat surprisingly, during this Bicentennial year. Printed 46-star flags from 1908 that used to sell for \$30 now go for \$45, but that's mainly due to inflation, according to Allentown, Pa., mail auctioneer George Rinsland.

Last month, Framingham, Mass., auctioneer Ben Corning sold a 16-star maritime flag from the period 1796-1803 made of homespun wool with hand-stitched stars (and some wind damage) for \$260; a 42-star flag with "Garfield and Arthur" printed on it brought \$209 at the same sale.

On Flag Day this Monday, John Wallach's American Folk Art Shop at 3214 O St. NW in Washington opens an exhibition and sale of antique flags. Several 13-star flags will be offered at prices between \$500 and \$950, depending mostly on condition, and 19th-century flags are priced between \$125 and \$500.

The outstanding book on the flag as art is Boleslaw and Marie Louise D'Etrange Mastai's "The Stars and Stripes" (Knopf, \$25). It is illustrated with photographs of their collection of 80 unique handmade flags, as well as embroideries, sheet music, needlecases, trade cards, and all kinds of souvenirs that feature the flag motif. Slides of their collection flash on and off a screen as you enter the new Living History Center on Independence Mall.

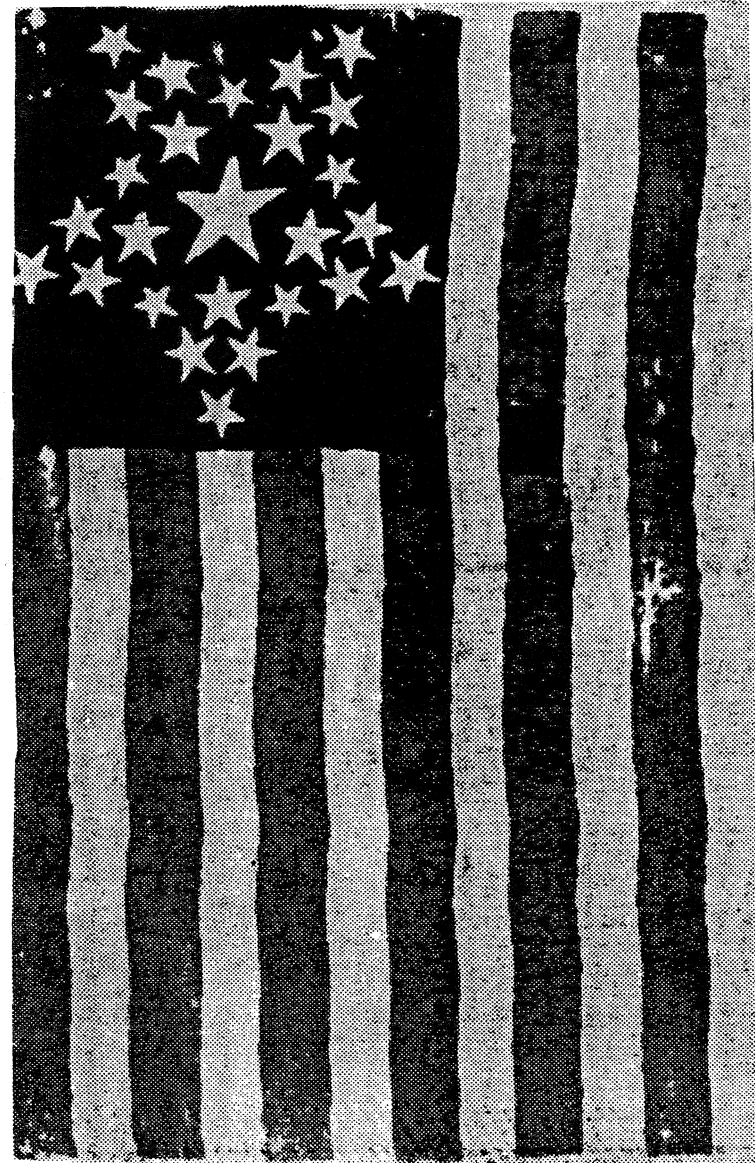

The Great Star Flag, using stars within a star, was made out of silk in 1837

from: *The Philadelphia Inquirer*
13 June 1976

THREE U.S. CITY FLAGS AND THE PHOENIX¹

by Dorothy Hite Claybourne

Art by Marianne Reamey

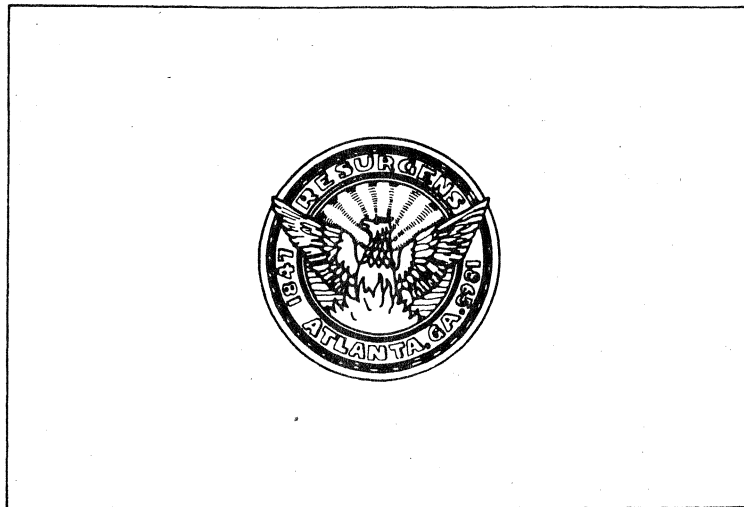

Charges in heraldry can be anything from a towered castle to a crane, from a beehive to a bezant, from a sloop under sail to a demi-sun in splendor. Since flags are an extension of basic heraldry finding such items as major devices on flags is not unexpected. Yet the author recently had notable serendipity on this subject in connection with a special study.

My research topic deals with civic heraldry, in particular flags of the U.S. cities, and, relevant to this matter here, the myth of immortality and resurrection of the phoenix, always shown heraldically on its pyre and rising from the flames. I often marvel at the repetitive manner in which Greek and Roman mythology comes up in daily living, although this ceases to startle when I recall what western civilization owes to them. The first thing that usually comes to mind is the words and phrases encountered in ordinary conversation and reading. But this penchant for the use of mythology is otherwise reflected in our society, and one such way is as symbols on flags.

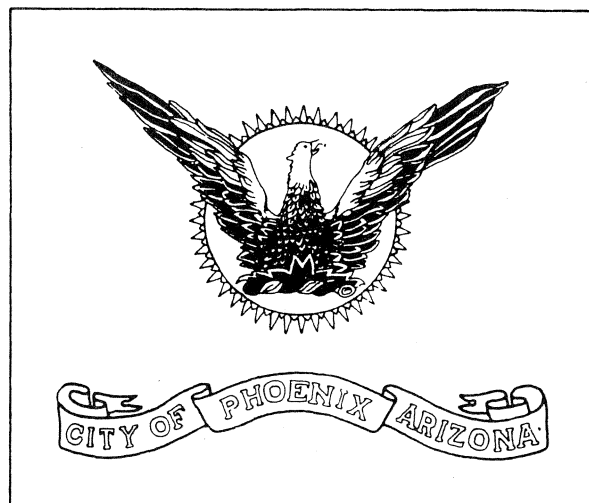

To retell the myth in this urban setting, the son (the recently rejuvenated city) rises new and young from the ashes of his father (the older city) who is now dead and at an end.

By and large, cities adopt civic flags at a time when the civic pride and spirit is ascending and city life has assumed a triumphal aspect; but three populous U.S. cities have as the prominent device on their city flags this triumphant mythical bird symbolizing the rebirth of the cities through previous destruction by fire. These are San Francisco, 13th largest metropolitan area; Phoenix, 20th in size; and Atlanta, 27th; according to the 1970 census. In all three instances, this symbolism of the undying city is historically meaningful to the populace.

Atlanta, capital city of Georgia, adopted in 1877 as a major part of its city seal this mythical bird which later was centered on a plain blue field as the city's flag, adopted in 1910. Here the phoenix marks the city's rehabilitation after its destruction by the federal armies in 1864 during the American Civil War.

San Francisco makes use of the crest from its official coat-of-arms (adopted in 1859), the mythical bird on a gold-bordered flag with a white background. The westcoast city was consumed by fire six times in four years during its infancy in the 1850's. Prophecically, the flag was adopted in 1899-1900, several years prior to an even greater disaster, the San Francisco earthquake and fire of 1906.

Atlanta and San Francisco began their reconstruction immediately, almost before the smoke had wafted away and the ashes had cooled, but Phoenix was not to be rebuilt until centuries after its origin. Also a state capitol, Phoenix is the city's name but the venerable bird appearing on its flag, centered on a plain blue field, is emblematic of more than merely what the place is called. A city indeed of ancient times, this desert site was rebuilt hundreds of years after its desertion from unknown causes by the early builders, the Hohokam Indians circa 400 B.C. The pioneer settlers found the prehistoric ruins in 1867 and made use of the original extensive irrigation canals in restoration. Hence, the Southwest Indian tribe predicted the phoenix-like rise of the new city, even more beautiful, from the ashes of the past, thus suggesting the name. Phoenix adopted its city seal in 1881 and its flag in 1921.

Thus, over each of these three contemporary U.S. cities waves a flag of singular significance and another example of encountering mythology in everyday life.

¹It is interesting to note that one of the United States, Hawaii, also makes appropriate use of this myth. The state seal bears a shield, the charge of which is a modified form of the Hawaiian monarchy's coat-of-arms, at the bottom is a phoenix rising from the flames amid clusters of taro, banana leaves, and maidenhair fern. The seal was adopted in 1959, the year Congress admitted Hawaii to statehood. Volcanoes, the destruction caused by their eruptions, and the aftermath of rebirth bespeak of the real meaning this mythic device has in the history of this eight island 50th State of the Union. The state flag is not armorial. The coterminous Honolulu city and county seal and flag has the state coat-of-arms differenced by an extinct volcano, Diamond Head, and a mountain pass, Nuuanu Pali, two celebrated views near the city, as pictorial supporters.

LETTERS

To The Editor

This is to report on an Acadian flag I saw in use in Nova Scotia this past week.

It is similar to the flag shown on page 303 of Dr. Smith's recent volume on flags, however, there are significant differences.

The proportions were 1:2 rather than 2:3. The five pointed star in the upper hoist is tilted so that the point of the star is aligned with the upper left corner of the flag rather than "standing" as in Smith's illustration.

This flag can be said to be in 'actual use' at the Evangeline Park at Grand Pre, Nova Scotia as it can be seen presiding over the memorial to the expelled Acadians (1755).

Yours truly,

G.M. KNUDSEN
Quincy, Massachusetts

.....

After several years as a member of NAVA, I finally believe I have something to communicate. I operate a business chiefly involved with flags, and I have seen many Bennington flags made by different manufacturers during the last couple of years and when there was no alternative, we made them ourselves.

All the time I wondered why the stars were so carelessly laid, going by the pictures in the "Stars and Stripes" by D'Otrange Mastai.

Watching the fireworks display on television, July 4th, triggered a thought and I found that the stars in the arch rise on the left and arch over the "76" and down the sinister side with the apex of each star pointing at the next, so the last star is pointing down and slightly inward. The two stars above the arch were pointing straight up.

If this is already known, the fact that none of the flags I checked had been faithful reproductions prompted me to write.

Yours sincerely,

MICHAEL A. HOWELL
Dana Point, California

.....

* Fr. David Drake-Brockman, The Missions to Seamen, P.O. Box 837, Suva, Fiji, has published a booklet entitled "Fiji Flags". Copies of the same are available for \$1.50, including postage.

* Paul Chadbourne Mills, a NAVA member, has published a booklet entitled "New Glory" - A Flag History and Design Project for the American Revolution Bicentennial / Part I: Colonial and Revolutionary Era Flags. Copies of the same may be had by writing the author at the Santa Barbara Museum of Art, 1130 State Street, Santa Barbara, California 93101.

* Beautiful lithographs of the flags of the United States and the flags of all nations contributing to the nation's birth, are available from Henry Hudson, P.O. Box 294, Palisades Park, N.J. 07650. Write for price list and details.

Flags and Symbols in the News

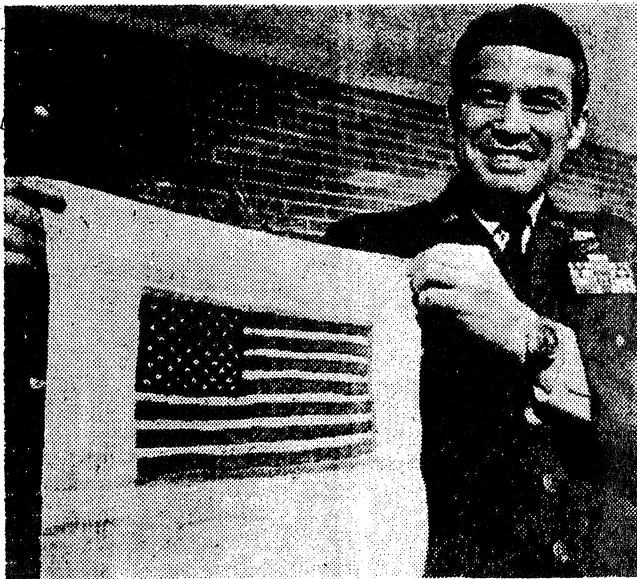

Lt. Col. John A. Dramesi displays PW-camp project
... at March 1973 news conference

A three-judge federal court in Washington, D.C. approved former President Richard Nixon's request that a U.S. flag made in a Hanoi prisoner of war camp be displayed in Philadelphia's July 4th Bicentennial parade.

Air Force Lt. Col. John Dramesi of Philadelphia made the flag during his six years as a POW. He smuggled it out of North Vietnam when he was released, and gave it to Nixon as a gift in 1974. He requested that the flag be given back to him for display.

It and most other items received by Nixon while president wound up in the custody of the General Services Administration as a result of a 1974 law stemming from the Watergate scandal, and it took a court order to have the flag released.



The flag of the Unitarian Church in Germany is shown above (to the right). The picture was taken at the site of the 1967 German Unitarian General Assembly in Hamlin.

The white symbol on a dark blue background signifies life. The same symbol displayed downwards means death, being one in the circle of the universe.



The logo to the left was the one used by the United Church of Christ in observance of the U.S. Bicentennial.

The Flag Is A Mystery But It Stirs Emotions

By ERMA BOMBECK

No one ever taught me about the flag. When I was 5 years old, I was in a dance recital. My costume was a silver leotard. Attached to it at the shoulders and wrists was a flag. During the last few bars, I spread my arms, revealing 48 stars on a field of white. The crowd went crazy cheering. I learned that a flag could make you look like you had talent.

A few years later at a baseball game

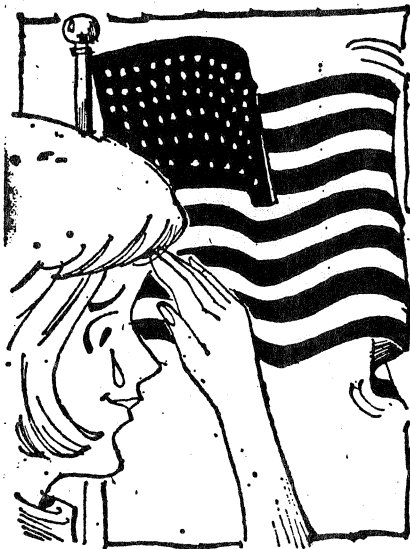

in Cincinnati, two men were calling one another names that would starch your underwear. One said Ted Kluszewski hit like a girl and the other guy threatened to rearrange his nose.

Just then, they hoisted the flag and both of them stood with their hats over their hearts. I learned that a flag could break up a fight.

During World War II, my Grandma

sent her son to war. I never saw her cry when he left, when he wrote, or when we talked about him, but one afternoon when she thought no one was watching, she went to the front window and put a little flag on the sill. There were flags all up and down the street in the windows. I learned that a flag could bring tears to the eyes of people who didn't usually cry.

When I was in New York once, I saw a group of demonstrators protesting the war. They lit a match to the flag. I watched in horror as the silk stripes curled in flames because I knew what was coming. Within minutes, there would be a bolt of lightning and thunder to strike them all dead. Nothing happened. The earth didn't part. The sky didn't fall. And the VFW was open regular hours. I learned that a flag could touch the ground and life could go on.

Later, I was to learn that people would make underwear out of the flag, keyrings and toilet seats. The flag was a successful commercial venture.

I would learn that you wouldn't think about the flag for a long time, then you'd see it being raised slowly over a gold medal winner at the Olympics and you'd get up out of your chair quickly and say, "Anyone want a beer while I'm up?" and go to the kitchen to hide your tears.

I'm still learning about the flag. It's an enigma to me. I've known it all my life. It's so familiar, yet it occasionally touches a nerve that excites to the point where I square my shoulders and say to a perfect stranger at the United Nations:

"See that one with the red and white stripes and the blue stars? That's my country."

from: The Pittsburgh Press
Pittsburgh, Pennsylvania
July 4, 1976

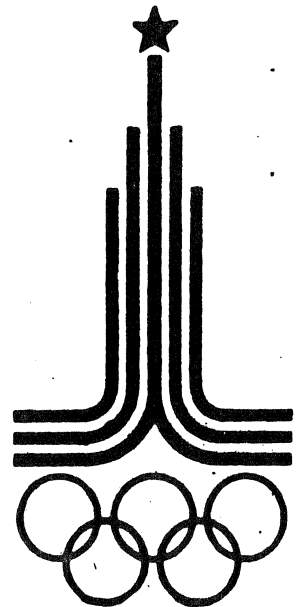

The emblem of the 1980 Olympics in Moscow.



Symbol of the 1976 Republican National Convention, U.S.A.



Logo used by the Roman Catholic Church in the U.S. in observance of the Bicentennial.

.....
OLD GLORY IS BIG BUSINESS

This is a big year for sales of the United States flag, according to reports from various manufacturing and sales sources.

Flag sales in this Bicentennial year are expected to reach the neighborhood of \$60 million, which would be about three times the 1975 sales figure.

from: Buffalo Courier Express
Buffalo, New York
August 23, 1976